

NOTES:

1. 50' OF CENTERLINE STRIPING ON EACH SIDE OF THE SPEED LUMP AND 12' ON TOP OF THE SPEED LUMP.
2. AVERAGE WIDTH OF STREET IS 37' EXCLUDING THE CURB AND GUTTER.

<h1 style="margin: 0;">CITY OF FREMONT</h1> <h2 style="margin: 0;">STANDARD DETAILS</h2> <h3 style="margin: 0;">SPEED LUMP</h3>			DATE APPROVED BY CITY COUNCIL 04/11/06			
			RESOLUTION NO. 2006-31			
			CITY ENGINEER			
FILE NO.	SCALE	DRAWN	CHECKED	DATE	DWG NO.	
TSD-5.dwg	NOT TO SCALE	SLM	EPE	12/2005	TSD-5	1 of 2

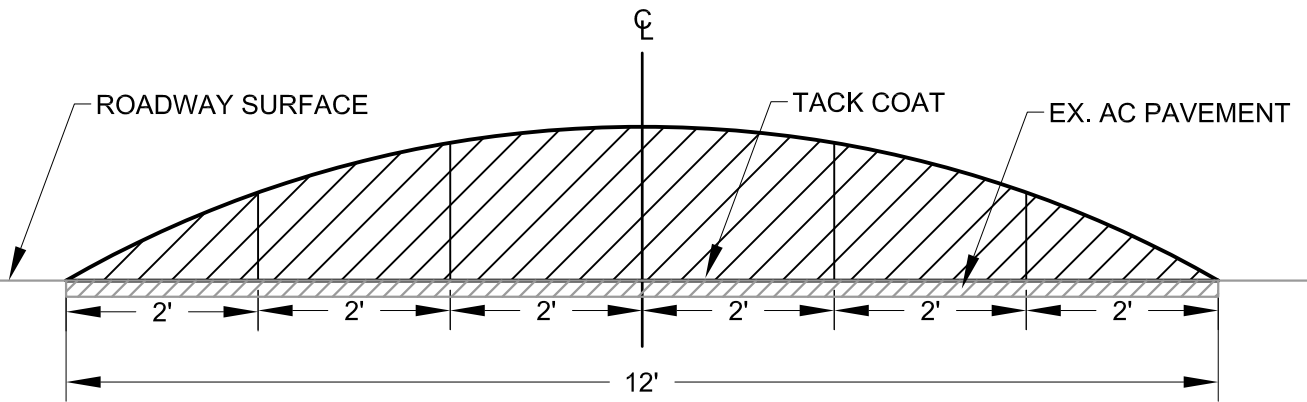

HEIGHT BEFORE COMPACTION	2 ¹ / ₈ "	3 ³ / ₈ "	3 ³ / ₄ "	3 ³ / ₈ "	2 ¹ / ₈ "
HEIGHT AFTER COMPACTION	1 ⁵ / ₈ "	2 ⁵ / ₈ "	3 "	2 ⁵ / ₈ "	1 ⁵ / ₈ "

TYPICAL PROFILE



SIGN ADJACENT TO SPEED LUMP
W17-1



ADVANCED WARNING SIGN
W17-1 AND W16-9P

NOTE:

1. SEE THE CITY OF FREMONT STANDARD DETAILS FOR THE INSTALLATION OF SIGN POSTS.
2. SEE MANUAL ON UNIFORM TRAFFIC CONTROL DEVICES (MUTCD) AND MUTCD CALIFORNIA SUPPLEMENT FOR SIGN DETAILS.

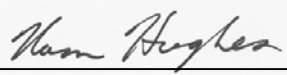
			CITY OF FREMONT STANDARD DETAILS			DATE APPROVED BY CITY COUNCIL 04/11/06			
						RESOLUTION NO. 2006-31			
			<u>SPEED LUMP</u>			 CITY ENGINEER			
NO.	REVISED	DATE				FILE NO.	SCALE	DRAWN	CHECKED
REVISIONS			TSD-5.dwg	NOT TO SCALE	SLM	EPE	12/2005	TSD-5	2 of 2